

- UPVC and ABS construction.
- 316 grade stainless steel components.
- Up to 10 BAR pressure rated.
- PVC-U body.
- Light body weight & single union structure.
- Handle can be used as tool to adjust threaded seal carrier.
- Female solvent socket.
- Metric series.
- Ball seat in HDPE.
- O-Rings in EPDM.
- Teflon seals.
- Quick installation.

NO.	PART	MATERIAL	QUANTITY
1	BODY	UPVC	1
2	STEM O-RING	EPDM	2
3	STEM	UPVC	1
4	BALL	UPVC	1
5	SEAT SEAL	TPE, TPV, TPO	2
6	CARRIER O-RING	EPDM	1
7	SEAL CARRIER	UPVC	1
8	UNION O-RING	EPDM	1
9	END CONNECTOR	UPVC	1
10	UNION NUT	UPVC	1
11	HANDLE	PVC	1

Product Details
Single union ball valve, socketed end, 20 mm 1/2" size, BS Std
Single union ball valve, socketed end, 25 mm 3/4" size, BS Std
Single union ball valve, socketed end, 32 mm 1" size, BS Std
Single union ball valve, socketed end, 40 mm 1 1/4" size, BS Std
Single union ball valve, socketed end, 50 mm 1 1/2" size, BS Std
Single union ball valve, socketed end, 63 mm 2" size, BS Std
Single union ball valve, socketed end, 75 mm 2 1/2" size, BS Std
Single union ball valve, socketed end, 90 mm 3" size, BS Std

Dimensions (in mm)

SIZE	1/2"	3/4"	1"	1-1/4"	1-1/2"	2"	2-1/2"	3"	4"
I	16.10	18.50	21.00	26.50	31.30	38.00	41.00	51.50	61.00
d1	20.30	25.30	32.30	40.30	50.30	63.30	75.30	90.30	110.40
d2	20.00	25.00	32.00	40.00	50.00	63.00	75.00	90.00	110.00
d	15.00	20.00	25.00	30.00	38.00	48.00	59.00	72.00	96.00
C	56.00	60.00	69.00	80.00	95.00	116.00	139.00	170.00	210.00
E	79.00	90.00	103.00	122.00	139.00	166.00	192.00	235.00	277.00
A	63.00	72.00	75.00	85.00	95.00	110.00	128.00	139.00	160.00
L	76.00	87.00	101.00	114.00	137.00	163.00	198.00	230.00	274.00
D	28.80	35.00	43.00	52.00	62.00	75.50	88.50	106.00	131.00

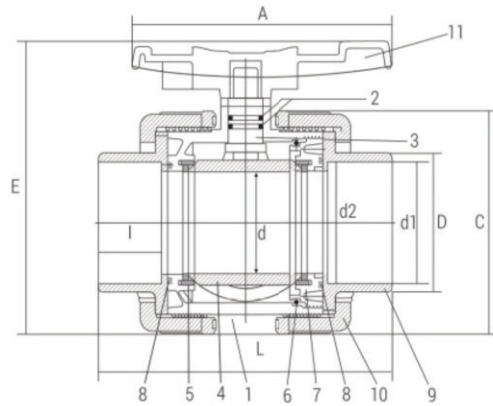
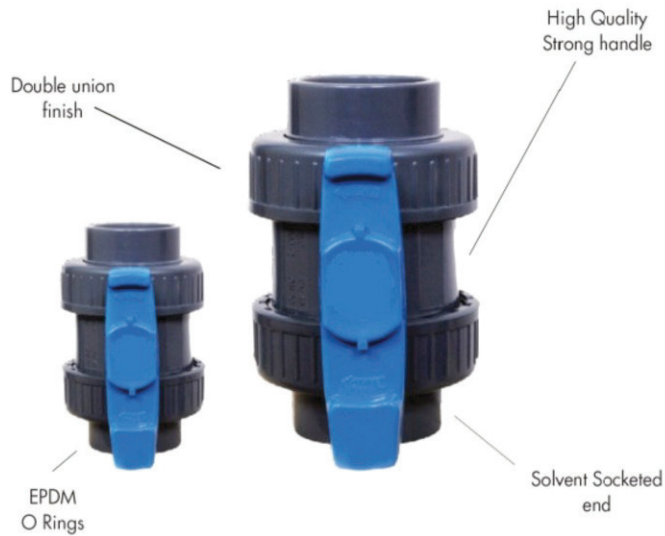

- UPVC and ABS construction.
- 316 grade stainless steel components.
- Up to 10 BAR pressure rated.
- PVC-U body.
- Light body weight & compact double union structure.
- Handle can be used as tool to adjust threaded seal carrier.
- Ball seat in HDPE.
- O-Rings in EPDM.
- Teflon seals.
- Quick installation.
- Metric series.
- Female solvent socket.

NO.	PART	MATERIAL	QUANTITY
1	BODY	UPVC	1
2	STEM O-RING	EPDM	2
3	STEM	UPVC	1
4	BALL	UPVC	1
5	SEAT SEAL	TPE, TPV, TPO	2
6	CARRIER O-RING	EPDM,	1
7	SEAL CARRIER	UPVC	1
8	UNION O-RING	EPDM	2
9	END CONNECTOR	UPVC	2
10	UNION NUT	UPVC	2
11	HANDLE	PVC, ABS	1

Product Details
Double union ball valve, socketed end, 20 mm 1/2" size, BS Std
Double union ball valve, socketed end, 25 mm 3/4" size, BS Std
Double union ball valve, socketed end, 32 mm 1" size, BS Std
Double union ball valve, socketed end, 40 mm 1 1/4" size, BS Std
Double union ball valve, socketed end, 50 mm 1 1/2" size, BS Std
Double union ball valve, socketed end, 63 mm 2" size, BS Std
Double union ball valve, socketed end, 75 mm 2 1/2" size, BS Std
Double union ball valve, socketed end, 90 mm 3" size, BS Std

ASTM std valves are also available

Dimensions (in mm)

SIZE	1/2"	3/4"	1"	1-1/4"	1-1/2"	2"	2-1/2"	3"	4"
I	16.10	18.50	21.00	26.50	31.30	38.00	41.00	51.50	61.00
d1	20.30	25.30	32.30	40.30	50.30	63.30	75.30	90.30	110.40
d2	20.00	25.00	32.00	40.00	50.00	63.00	75.00	90.00	110.00
d	15.00	20.00	25.00	30.00	38.00	48.00	59.00	72.00	96.00
C	56.00	60.00	69.00	80.00	95.00	116.00	139.00	170.00	210.00
E	79.00	90.00	103.00	122.00	139.00	166.00	190.00	235.00	277.00
A	67.00	78.00	87.00	102.00	120.00	146.00	178.00	210.00	250.00
L	83.00	94.00	107.00	122.00	146.00	171.00	210.00	246.00	283.00
D	28.80	35.00	43.00	52.00	62.00	75.50	88.50	106.00	131.00